

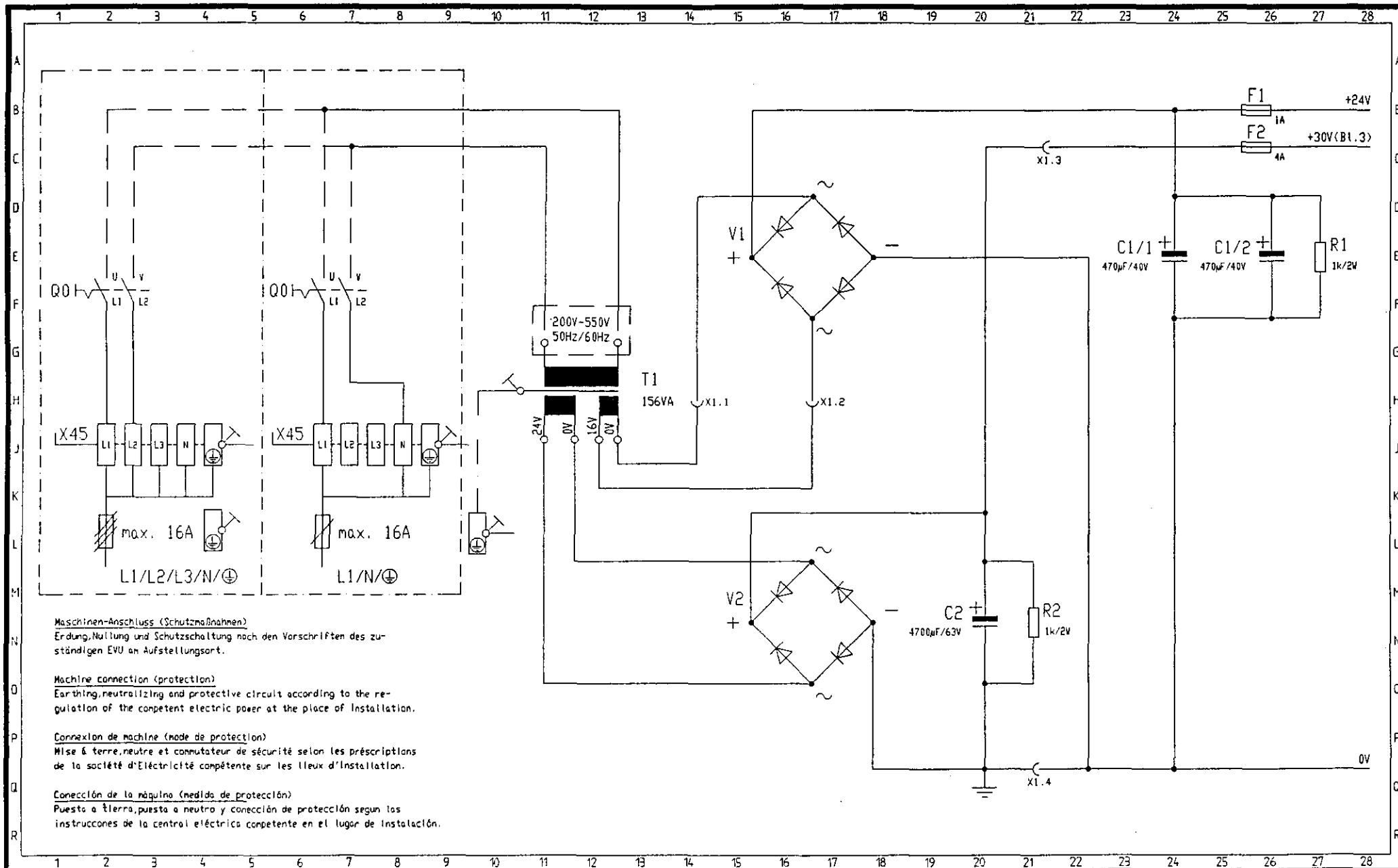

Stromlaufplan

Circuit diagramm

FSW 72 M



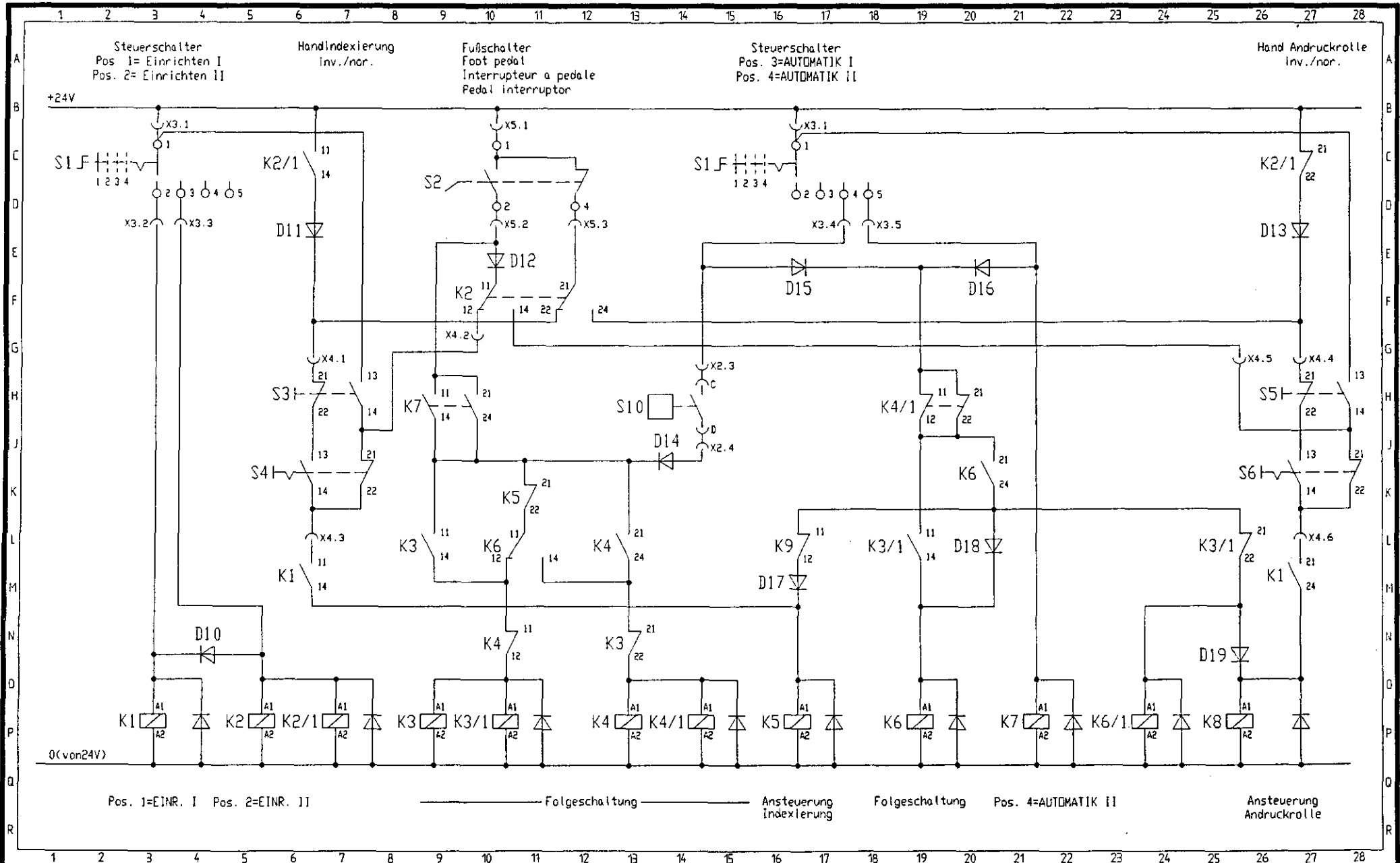

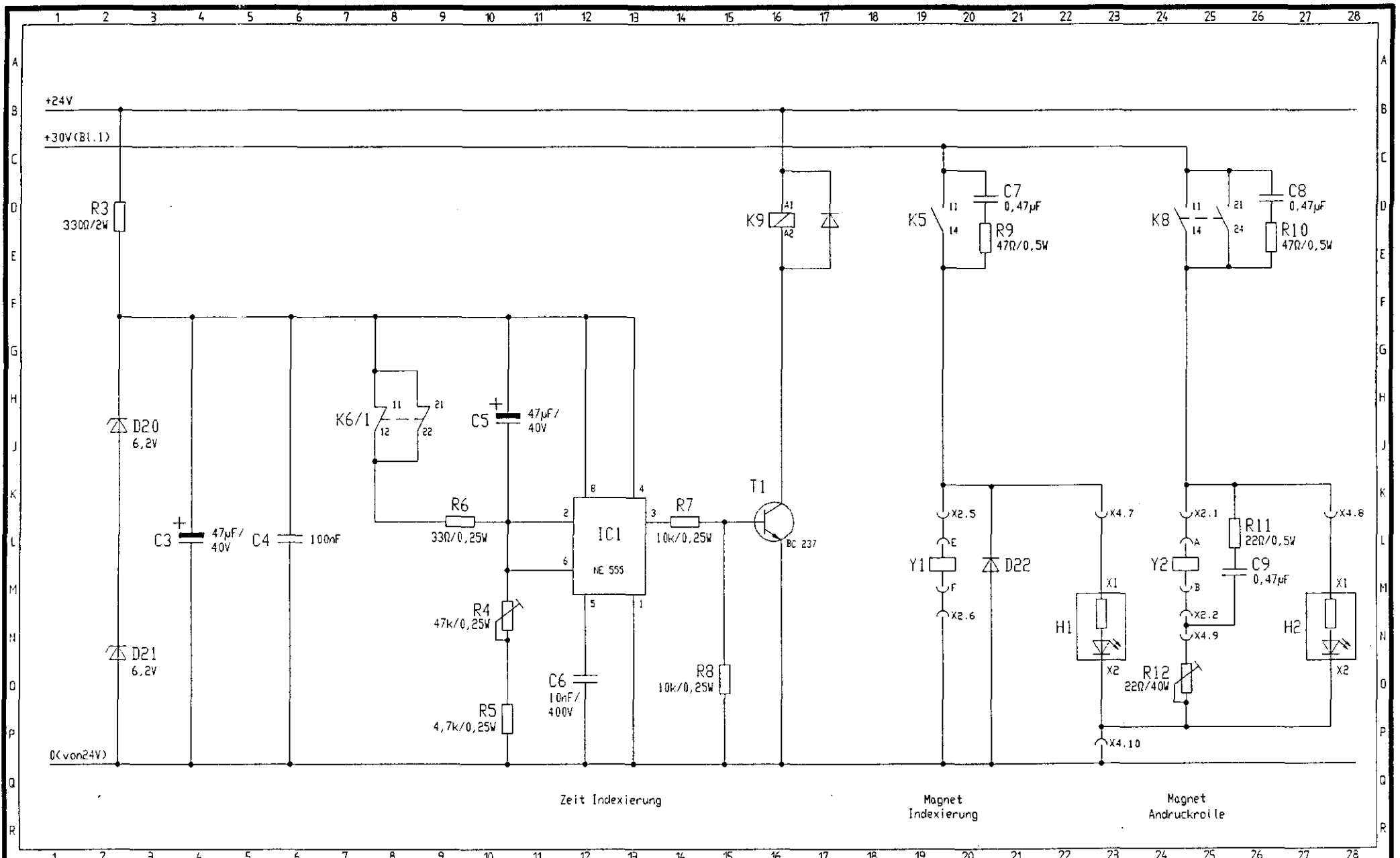

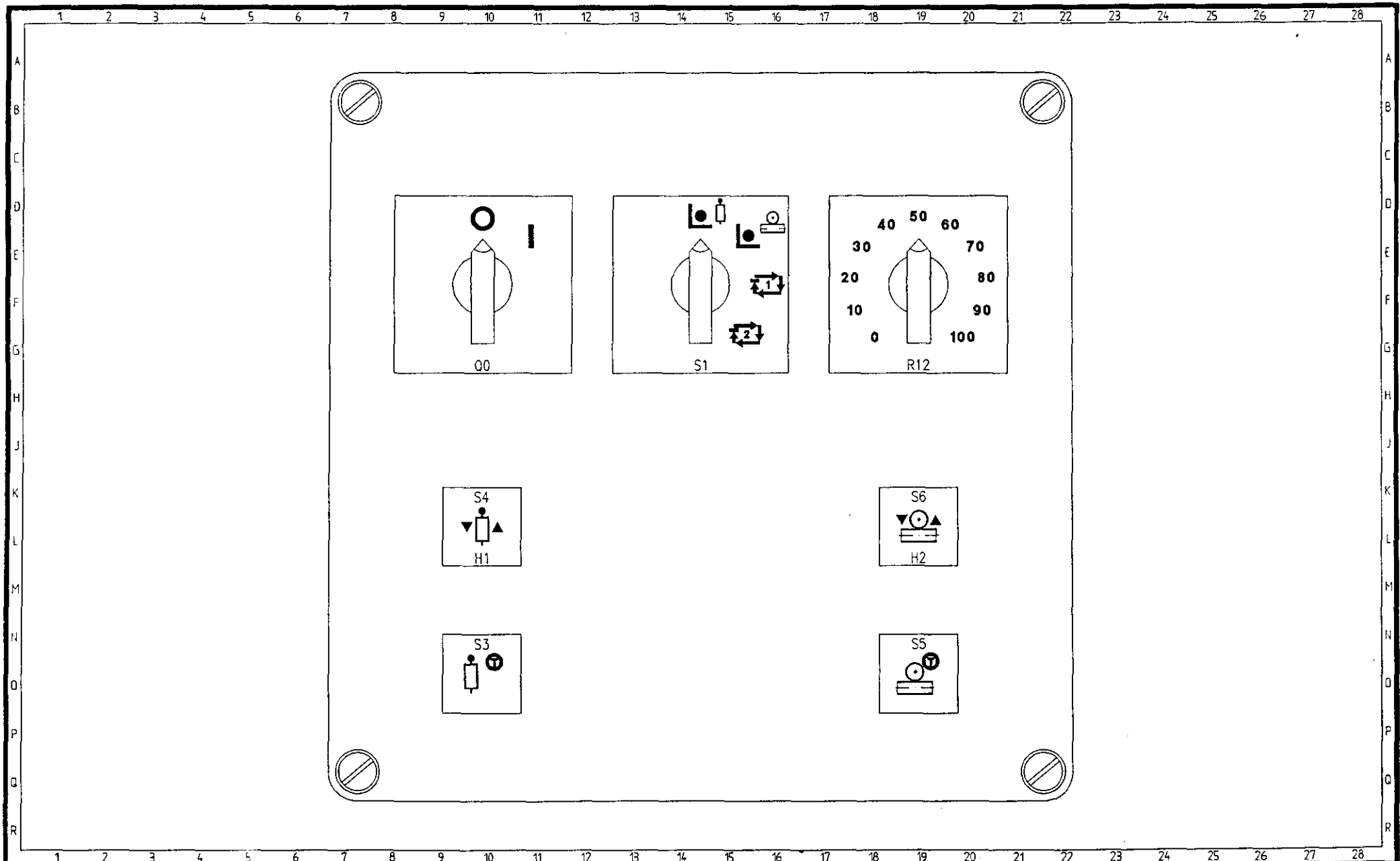

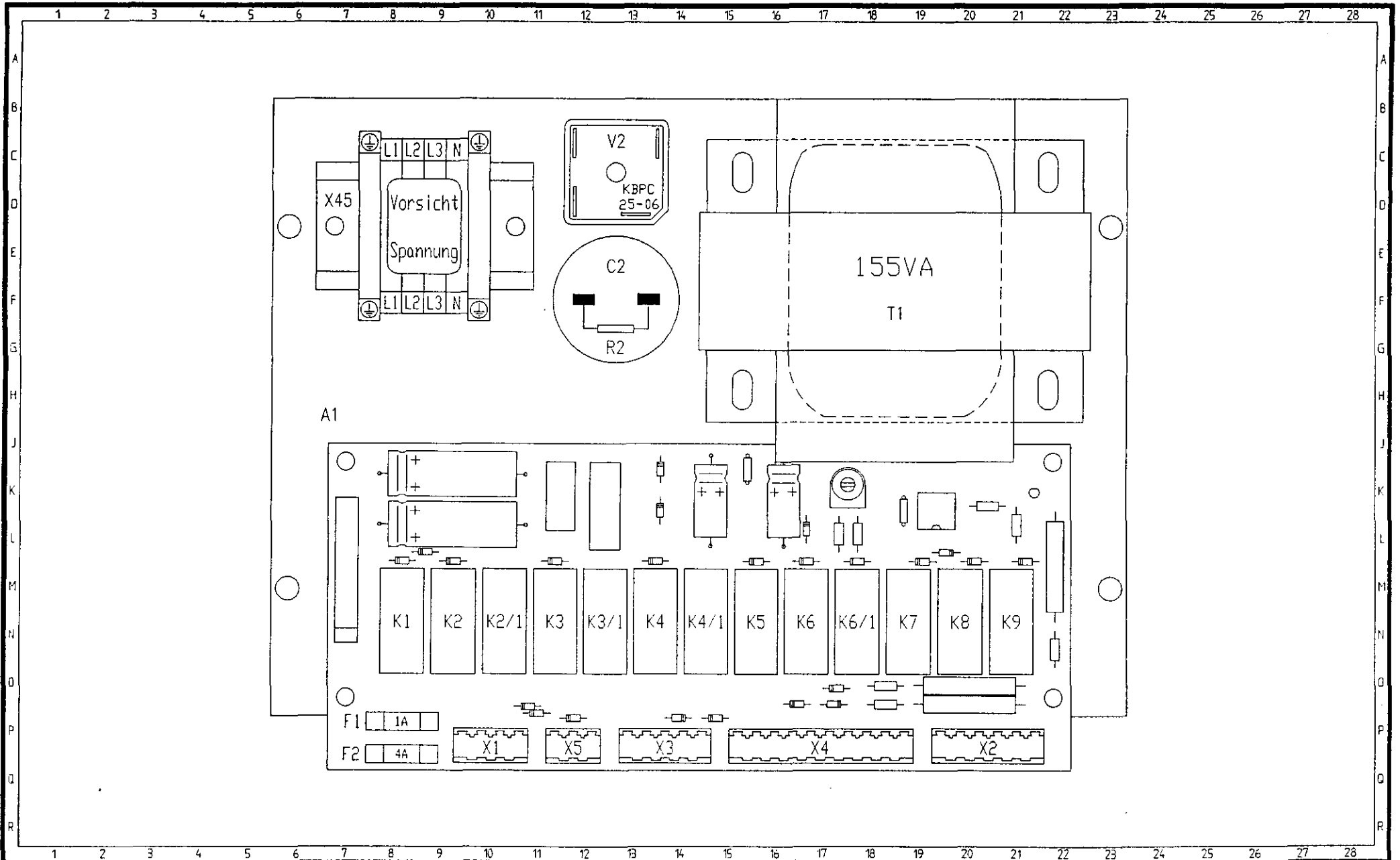

15. Elektro-Geräteliste
elektrical items list**Liste des appareils électriques**
Lista de aparatos eléctricos

Elektro-Ersatzteilliste

electric spare parts list

liste de pièces détachées électriques
lista de piezas de repuesto eléctricas

Pos.Nr	Benennung name désignation denominación	Gerätetype type type modelo	Teile-Nr. Part.-No. pièce No. partes Nr.	Spannung voltage tension tensión	Fabrikat make marque producto
A1	Relaisplatine board Platine Tarjeta		450 886-01		Vollmer
C2	Kondensator Capacitor Condensateur Condensador	4700µF, 63V	222 194		Röder- stein
F1	Sicherungseinsatz fuse link Cartouche fusible Cartucho fusible	M1,0A	222 413		Efen
F2	Sicherungseinsatz fuse link Cartouche fusible Cartucho fusible	M4,0A	222 429		Efen
Q0	Ausschalter Off switch Commutateur disjoncteur Interruptor de desconexión	BVNA2-0B10	225 421		Elektra
R2	Widerstand Resistor Résistance Resistencia	1K 4,5W	223 277		Bürklin
R12	Potentiometer Potentiometer Potentiomètre Potenciómetro	22/40W DP55/40	264 562		Bürklin
S1	Stufenschalter Step switch Commutateur à gradins Interruptor de niveles	BS1/1X8K	222 754		EBE- GmbH
S2	Fußschalter Foot pedal Interrupteur à pédale Pedal interruptor		450 876-01		Vollmer

Pos.Nr	Benennung name désignation denominación	Gerätetype type type modelo	Teile-Nr. Part.-No. pièce No. partes Nr.	Spannung voltage tension tensión	Fabrikat make marque producto
S3, S5	Drucktaster Pushbutton Bouton poussoir Pulsador	AT QXJT T25 DKL 300	222 762 222 720 222 760		Schlegel
S4, S5 H1, H2	Leuchtdruckschalter Illuminated pressure switch Manocontacteur limineux Pulsador luminoso	AFL2 QXJT+SL T25 DKL 300 L5,5k24y	222 746 222 721 222 760 221 719		Schlegel
S10	Mikroschalter Microswitch Micro-rupteur Microinterruptor	V3S	225 396		Völmle & Rickert
T1	Universal-Steuertransformator Universal control transformer Transformateur de commande universel Tranformador de mando universal	CMS11M 43.3-4b 155VA	215 747	200-570V	Vollmer
V2	Gleichrichter Rectifier Redresseur Rectificadores	GBPC 2506 25A/600V	221 886		Semikron
X120	Stecker Plug Prise mâle Conector macho	1-20 UNEF-2B 16S	258 858		ITT Cannon
X120	Steckdose Socket Prise de courant Base de enchufe	1-20 UNEF-2A 16S	258 857		ITT Cannon
X45	Klemmenleiste Terminal strip Bornier Regleta de bornes		450 885		Conta- Clip
X1, X2, X3, X4 X5	Stecker Plug Prise mâle Conector macho	BLA 4 BLA 6 BLA 5 BLA 10 BLA 3	246 146 246 148 246 147 246 150 247 231		Weid- müller
Y1	Elektro-Haftmagnet Electromagnetic clamp Electro-aimant adhérent Fijador electromagnético	GHBx6082.11/ B0100-28 24V; 100%ED; S=6mm	258 130		Thoma

Pos.Nr	Benennung name désignation denominación	Gerätetype type type modelo	Teile-Nr. Part.-No. pièce No. partes Nr.	Spannung voltage tension tensión	Fabrikat make marque producto
Y2	Elektro-Haftmagnet Electromagnetic clamp Electro-aimant adhérent Fijador electromagnético	FSW 72M 2-30 24V; 100%ED	258 106		Thoma