



Tel: +1.480.991.9445
 sales@novatechonline.com
 www.novatechonline.com

Tool Cutter Grinder : CM-2 MONASET

Starting at only **\$33,580.00** FOB CA

Specification

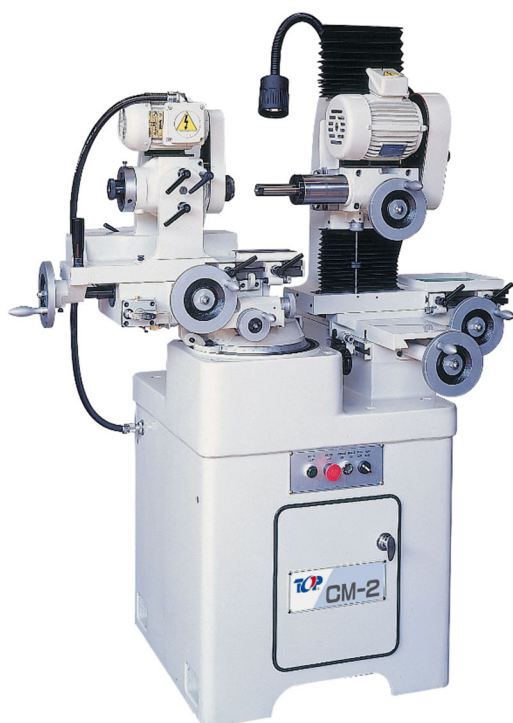

Atrump Machinery has always offered Highest Quality Standards Since 1989.

WORKHEAD CAPACITY	
SWING OVER MAIN SLIDE DIA	12" (Max)
COLLET WORK DIA	1.25" (Max)
COLLET WORK DIA	0.19" (Min)
SPIRAL ANGLE	60° (Max)
DISTANCE BETWEEN SPEAK OF SPINDLE	3.93° (Max)
DISTANCE BETWEEN CENTER OF TAILSTOCK	5.98° (Max)
GRINDING WHEELHEAD CAPACITY	
GRINDING DIAMETER	3.93° (Max))
WORKHEAD RANGE	
SLIDE TRAVEL	5.11"
OFFSET SLIDE TRAVEL	3.93"
FRONT OF CENTER	1.96"
REAR OF CENTER	1.96"
ANGLE ADJUSTMENT OF WORKHEAD	
ROTATION OF HORIZONTAL PLANE	±105° (210°)
ROTATIONAL OF VERTICAL PLANE	±40°
GRINDING WHEELHEAD RANGE	
SLIDE TRAVEL	4.33"
VERTICAL SILIDE TRAVEL, TOTAL	9.44"
ABOVE CENTER	4.33"
BELOW CENTER	5.11"
CROSS SLIDE TRAVEL	6.7"
FRONT OF CENTER	2.75"
REAR OF CENTER	3.93"
SPINDLE SPEED	
WORKHEAD SPEED	360rpm
WHEELHEAD, THREE SPEEDS	4000,6000 &8000rpm
MOTOR	
WORKHEAD AC	1/4 HP
GRINDING WHEELHEAD AC	1/2 HP
DIMENSION	
FLOOR SPACE	65"x45"x64.7"
NET WEIGHT	1895 lbs

- Quality assume by ISO 9002 & CE standard.
- Precisely grind, sharpen, recondition complex tools & cutters.
- Casting base to reduce vibration
- Precise Ball screw using grinding wheel side X and Y axis.
- Precise grinding acme lead screw using the other entire axis.
- Super precision class 7 bearing at spindle.
- The Monaset Grinder's combination of swiveling, turntable and moveable off set silde.
- Provide your shop with versatile capability to quickly set up and accurately generate convex and concave radii of varying size.
- Made in Taiwan.

Novatech Inc

Tel:+1.480.991.9445
 sales@novatechonline.com
 www.novatechonline.com

Tool Cutter Grinder : CM-2 MONASET

Machine Standard

17pcs collect set and spring-loaded index pawl
Wheelhead toothrest assembly with extension bar
Grinding wheel guards with extension bar
Front stock support, Diamond holder bracket
Wrench for workhead
Toothrest entering gauge
Adjustable tailstock support unit
Spanner for grinding wheel
Leveling blocks
Standard arbor
Screw driver
Set of wrenches
Double-end spanner
Set of (4) index plates for spiral lead Mechanisms 0,8,10&12 divisions
Tool box, Oil bottle
Grinding wheel (one each of straight, flaring cup and dish shape)
Additional diamond truing tool with diamond nib
1/2" wheel flange and spanner
4 standard Wheel flanges and one extension
Halogen work light
One shot lubrication

Machine Options

3-CM2-OPT01	Large cutter radius grinding attachment	\$860
3-CM2-OPT02	4" universal 6-jaw chuck for workhead	\$1,360
3-CM2-OPT03	Additional Index Plates, please specify size: (each)	\$460
3-CM2-OPT04	Additional Diamond Turning Tool with Diamond Nib	\$70
3-CM2-OPT06	Spring Loaded Index Pawl	\$570
3-CM2-OPT07	Additional Straight Cylindrical Collets (indicate sizes) (each)	\$330 PER EA
3-CM2-OPT08	Set of 3 Taper Collet #5, #7, #9 Brown & Sharpe	\$380
3-CM2-OPT09	Additional Straight Cylindrical Collets (inch 17 pcs.)	\$2,310
3-CM2-OPT10	Additional Straight Cylindrical Collets (metric 10 pcs.)	\$1,680
3-CM2-OPT11	Extra Set of 3 Grinding Wheels (4" x 1/2" straight, 4" x 1/2" dish & 3-1/2" x 1-1/2" flaring cup)	\$70
3-CM2-OPT13	Dust collector – 1/2 HP	\$1,680
3-CM2-OPT14	Dust collector – 1 HP	\$1,750
3-CM2-OPT15	Frequency inverter for grinding wheel spindle-1HP	\$800
3-CM2-OPT16	Frequency inverter for grinding wheel spindle-2HP	\$900
3-CM2-OPT17	Upgrading grinding wheel-spindle motor to 2 HP	\$800



Tel:+1.480.991.9445
 sales@novatechonline.com
 www.novatechonline.com

Tool Cutter Grinder : CM-2 MONASET

FLOOR PLAN

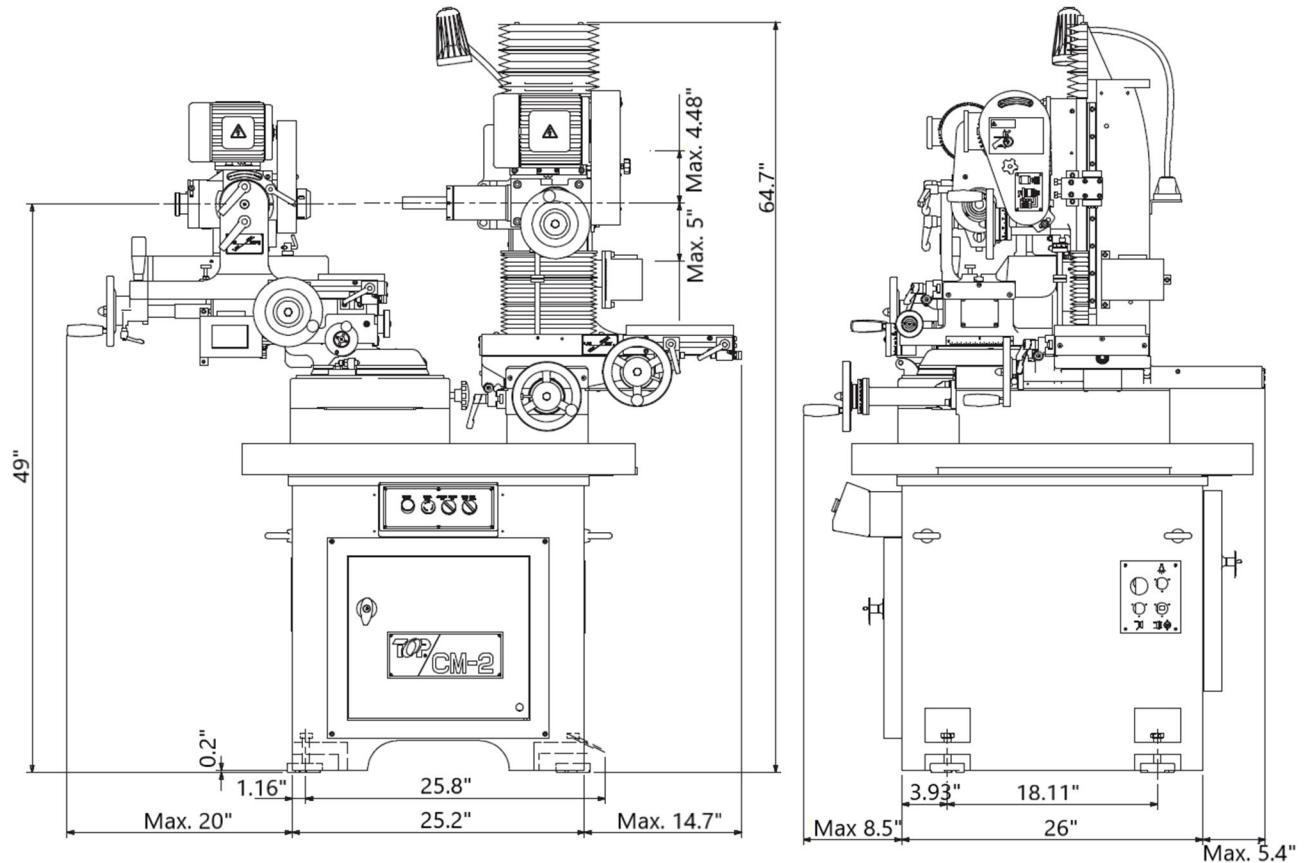

Terms & conditions

F.O.B.: Pomona, CA 91768
 Delivery: Please check with Novatech Sales Team

Standard Terms of Payment: 30% down-payment, balanced due before machine shipment.
 Taxes: Federal, State, Local Taxes are the responsibility of Purchaser.

Validity: This proposal is valid for 30 days.

Warranty: One-year limited warranty for any defects in material or workmanship of machine tool and factory installed components.

Visit for full warranty details & contract.

** WE RESERVE THE RIGHT TO CHANGE DESIGN, COLOR, SPECIFICATIONS, OR PRICE WITHOUT NOTICE **