



**NovatechOnline.com**

Tel:+1.480.991.9445  
sales@novatechonline.com

## **Universal Tool Cutter Grinder: M40**

**Starting at \$25,850.00** FOB CA

### Specification

<b>CAPACITY</b>	
LONGITUDINAL MOVEMENT OF TABLE	15.7"
DISTANCE BETWEEN CENTER	27.5"
CROSS MOVEMENT OF SADDLE	9.8"
WORKHEAD TAPER	MT#5 NT50 or BT50
<b>TABLE</b>	
T-SLOT	0.59"(+0.0019"~+0.0039"
TABLE WORKING RANGE	5.47" x 37"
WHEEL SPEED	2600, 3700, 6200rpm
WHEEL MOTOR	
<b>RANGE OF MOVEMENT</b>	
ROTATIVE ANGLE OF TABLE	±60°
JOG ADJUSTMENT OF TABLE	±10°
VERTICAL MOVEMENT OF WHEELHEAD	9.8"
SLOPE OF WHEELHEAD	±15°
ROTATIVE ANGLE OF WHEELHEAD	360°
DISTANCE BETWEEN CENTER OF SPINDLE AND TABLE	Max. 11.8" min. 1.96"
DISTANCE BETWEEN CENTER OF SPINDLE AND T-SLOT	Max. 16.3" min. 6.5"
<b>DIMENSION</b>	
FLOOR SPACE	61"x68"x58"
NET WEIGHT	2560 lbs

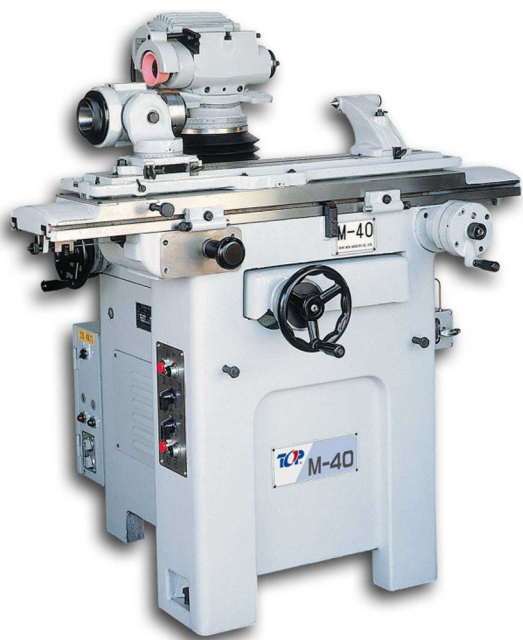

### **HIGHLIGHT**

- Tilting wheel head for easy clearance setting
- Universal work head to obtain the most suitable angle for a specific grinding job.
- Accurate, Versatile table
- Hardened and ground ways
- Anti friction slide way bearings
- Super precision match sets class 7 bearing at spindle
- Centralized lubrication which lubricates all the required points
- Made in Taiwan, quality certified by ISO 9002 & CE standard
- Adapted with opt. Attachments to do light O.D./I.D./Surface grinding

*Atrump Machinery has always offered Highest Quality Standards Since 1989.*

#### **Inclination of Wheelhead**

The wheelhead can easily tilt up to ±15 degrees, with a 360-degree swivel on the horizontal plane. The wheelhead can grind any angle as the operator request.

Two pairs of angular contact ball is designed to supported the spindle, bearing and tighten by nuts. The inner of wheel spindle has greased with lubricant and therefore doesn't additional lubricant is needed.







# NovatechOnline.com

Tel: +1.480.991.9455  
sales@novatechonline.com

## Machine Options *Universal Tool Cutter Grinder: M40*

3-M40-OPT01	Face mill grinding attachment	\$4,250
3-M40-OPT02	Radius grinding attachment (NO.01 Radius 0-50mm)	\$5,330
3-M40-OPT03	Radius grinding attachment (NO.02 Radius 0.25mm)	\$4,700
3-M40-OPT04	Helical grinding attachment (Work Spindle: MT4)	\$5,330
3-M40-OPT05	Cylindrical grinding attachment-Includes 4" 3-jaw Chuck & Back Plate	\$1,600
3-M40-OPT06	Internal grinding attachment	\$3,450
3-M40-OPT07	Work head indexing attachment	\$1,030
3-M40-OPT08	Extended grinding attachment	\$2,495
3-M40-OPT09	Surface grinding attachment	\$1,285
3-M40-OPT10	Drill pointing attachment	\$5,330
3-M40-OPT11	Lathe & planer tool Grinding attachment	\$1,175
3-M40-OPT12C	5C Collet Adapter for M40 Workhead	\$880
3-M40-OPT12I	Spring Collet chuck 1/4" – 1" (Inch)	\$1,070
3-M40-OPT12M	Spring Collet chuck 6-25 mm (Metric)	\$1,070
3-M40-OPT13	Wet grinding attachment – without Splash Plate	\$1,175
3-M40-OPT14	Dust collector	\$1,680
3-M40-OPT15	Hydraulic Power Feed Device (X axis) –Must be ordered and completed in Taiwan	\$8,155

## FLOOR PLAN

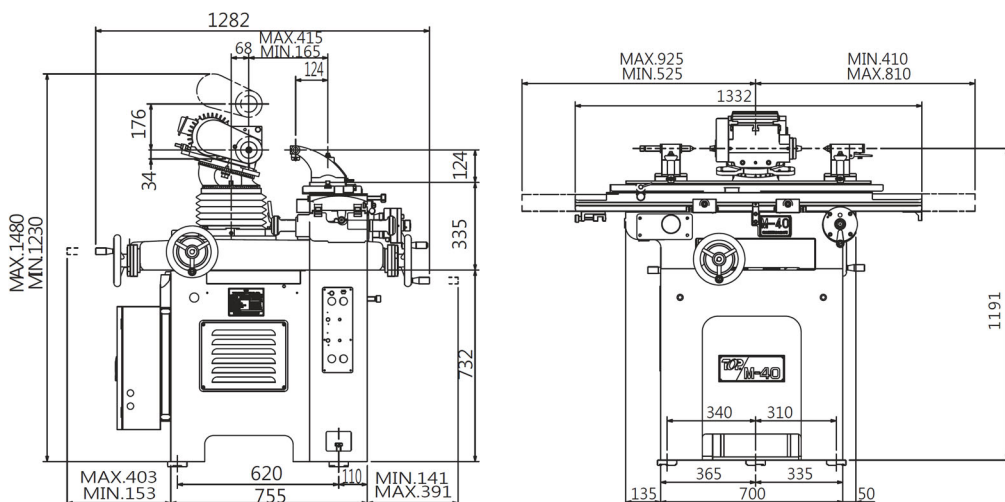

UNIT:mm

## Terms & conditions

F.O.B.: Pomona, CA 91768  
Delivery: Please check with Novatech Sales Team

Standard Terms of Payment: 30% down-payment, balanced due before machine shipment.

Taxes: Federal, State, Local Taxes are the responsibility of Purchaser.

Validity: This proposal is valid for 30 days.

Warranty: One-year limited warranty for any defects in material or workmanship of machine tool and factory installed components.

Visit for full warranty details & contract.

\*\* WE RESERVE THE RIGHT TO CHANGE DESIGN, COLOR, SPECIFICATIONS, OR PRICE WITHOUT NOTICE \*\*